

VersaFire® Direct-Vent Fireplace Systems

WELCOME HOME TO WARMTH



About VersaFire®

After 20 years of design and technological improvements, gas fireplaces of even just a few years ago pale in comparison to those being designed today. In a few more years, the same will be true when looking at today's models.

Vantage Hearth's VersaFire® makes our fireplaces "future proof" because they're upgradeable. So, when performance or appearance make your fireplace obsolete or you just want to change the look, a VersaFire® fireplace can be brought up to speed simply and inexpensively.

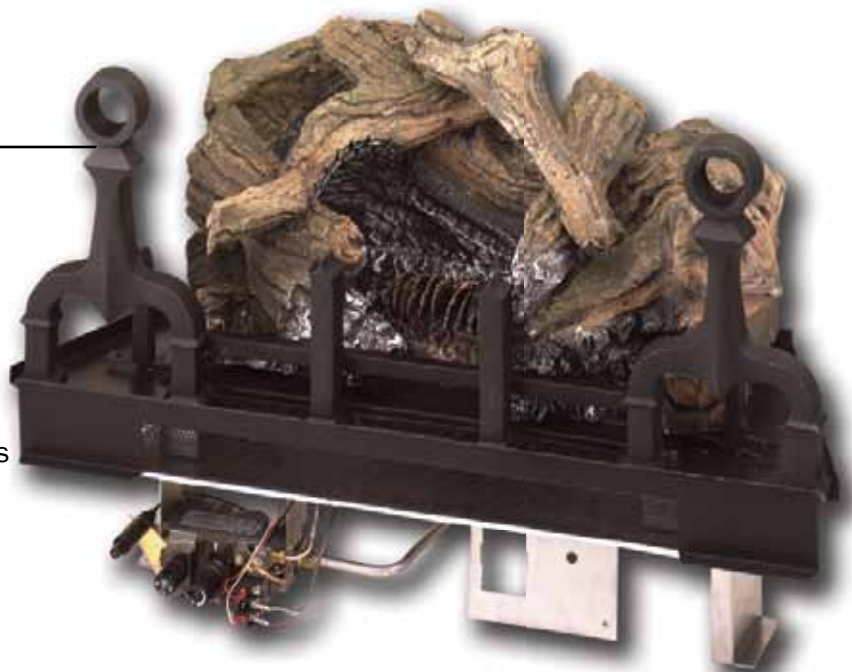

The "Premium's" massive split oak gas log set is a "mature" fire presentation with deep glowing coals and embers.



"Value" model burner/log modules feature split oak ceramic fiber logs in a "campfire" style arrangement.



"Performance" models include split oak logs and burnt down remnants with a random look.

Easy Installation



The Value, Performance and Premium burner designs are all sized to fit the mounting recess in the common fireplace chassis.



The burner is easily secured to the hearth floor with a series of perimeter screws.



The fully unitized log set is then placed snugly over the burner. The system is just as easily removed and replaced with a new burner and log set.



Value

Vantage Hearth's "Value" fireplace system leads the way in the direct-vent category of our exciting VersaFire® Series with campfire style logs, a beautiful glowing ember bed, and glowing highlights. The "Value" is an exceptional system with an impressive flame presentation and is the ideal match for today's energy-efficient homes.

Performance

The "Performance" is the centerpiece of our VersaFire® Series and features random split oak logs and remnants with exquisite detail and glow. Note the random multi-tiered flame pattern and realistic glowing ember bed burner...plus real woodburning log grate with andiron enhancers.



Our hinged, toolless entry door swings open for easy cleaning and never needs adjustment.

Premium

Fully loaded and truly impressive, Vantage Hearth's "Premium" is the flagship product of our VersaFire® Series, and sets tough new standards for any gas fireplace. The innovative "Premium" captures all the latest visual and functional technologies, features and conveniences available. Premium models feature beautiful cast iron grate treatments and andirons.



Flex gas connector, shut-off valve and pre-wired "J" box are all standard.

VersaFire® Direct-Vent Fireplace Systems

PRODUCT SPECIFICATIONS

MODEL	DESCRIPTION	SHIPPING WEIGHT
VERSAFIRE® UPGRADEABLE FIREPLACE SYSTEMS		
VTC36N1/P1	36" Value Direct-Vent Fireplace w/Rolled Louvers, Millivolt	120.0 lbs.
VTC36NB1/PB1	36" Value Direct-Vent Fireplace w/Rolled Louvers, Millivolt	175.0 lbs.
VTC36NH-HA	36" Value Direct-Vent Fireplace w/5/8" Pipe, Natural Gas, Black Interior, Stamped Louvers, High Altitude	175.0 lbs.
VTC36NB-HA	36" Value Direct-Vent Fireplace w/5/8" Pipe, Natural Gas, Stacked Brick Refractories, Stamped Louvers, High Altitude	175.0 lbs.
VVC36N1/P1	36" Performance Direct-Vent Fireplace, Millivolt - Black Metal Interior	120.0 lbs.
VVC36NB1/PB1	36" Performance Direct-Vent Fireplace, Millivolt - Refractory Brick Lined Interior	175.0 lbs.
VVC36NH1/PH1	36" Performance Direct-Vent Fireplace, Millivolt - Herringbone Brick Lined Interior	175.0 lbs.
VVC42N1/P1	42" Performance Direct-Vent Fireplace, Millivolt - Black Metal Interior	145.0 lbs.
VVC42NB1/PB1	42" Performance Direct-Vent Fireplace, Millivolt - Refractory Brick Lined Interior	215.0 lbs.
VVC42NH1/PH1	42" Performance Direct-Vent Fireplace, Millivolt - Herringbone Brick Lined Interior	215.0 lbs.
VKC36N1/P1	36" Performance Direct-Vent Fireplace w/Refractory Brick Liner, Millivolt	175.0 lbs.
VKC36NH1/PH1	36" Performance Direct-Vent Fireplace w/Herringbone Refractory Brick Liner, Millivolt	175.0 lbs.
VKC42N1/P1	42" Premium Direct-Vent Fireplace w/Refractory Brick Liner, Millivolt	215.0 lbs.
VKC42NH1/PH1	42" Premium Direct-Vent Fireplace w/Herringbone Brick Liner, Millivolt	215.0 lbs.
VERSAFIRE® UPGRADEABLE CHASSIS		
VDVC36	36" Fireplace Chassis, Painted Black Interior	95.0 lbs.
VDVC36B	36" Fireplace Chassis with Stacked Brick Refractory	145.0 lbs.
VDVC36H	36" Fireplace Chassis with Herringbone Brick Refractory	145.0 lbs.
VDVC42	42" Fireplace Chassis, Painted Black Interior	140.0 lbs.
VDVC42B	42" Fireplace Chassis with Stacked Brick Refractory	195.0 lbs.
VDVC42H	42" Fireplace Chassis with Herringbone Brick Refractory	195.0 lbs.
VERSAFIRE® UPGRADEABLE BURNER/LOG MODULES		
DVM36TN/P	36" Value Direct-Vent Burner & Log Module, Millivolt	60.0 lbs.
DVM36TNE/TPE	36" Value Direct-Vent Burner & Log Module, Electronic Ignition	60.0 lbs.
DVM36VN/P	36" Performance Direct-Vent Burner & Log Module, Millivolt	70.0 lbs.
DVM36VNE/VPE	36" Performance Direct-Vent Burner & Log Module, Electronic Ignition	70.0 lbs.
DVM42VN/P	42" Performance Direct-Vent Burner & Log Module, Millivolt	76.0 lbs.
DVM42VNE/VPE	42" Performance Direct-Vent Burner & Log Module, Electronic Ignition	76.0 lbs.
DVM36KN/P	36" Premium Direct-Vent Burner & Log Module, Millivolt	85.0 lbs.
DVM36KNE/KPE	36" Premium Direct-Vent Burner & Log Module, Electronic Ignition	85.0 lbs.
DVM42KN/KP	42" Premium Direct-Vent Burner & Log Module, Millivolt	95.0 lbs.
DVM42KNE/KPE	42" Premium Direct-Vent Burner & Log Module, Electronic Ignition	95.0 lbs.

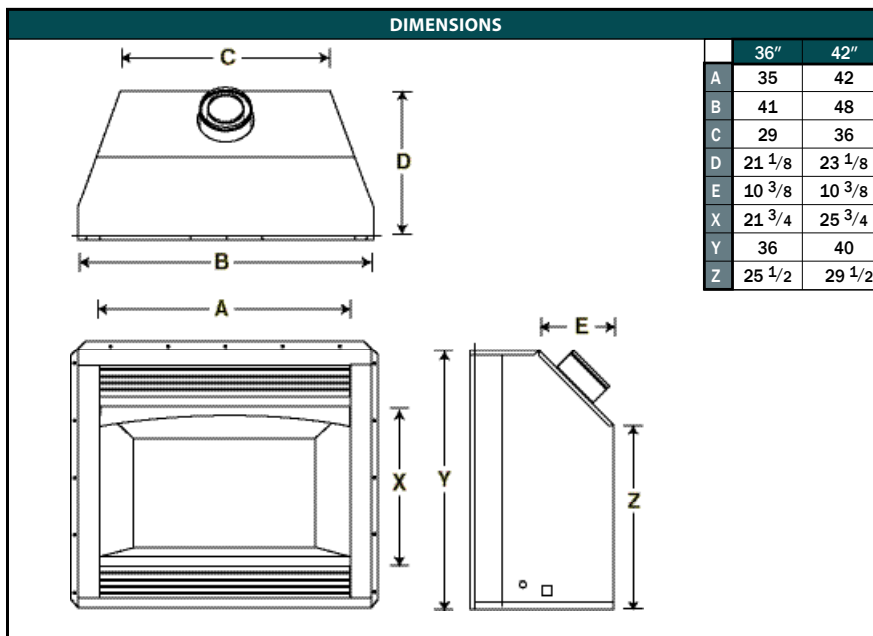

Note: All measurements are in inches. Dimensions on this catalog are approximate. For accurate dimensions, refer to the installation instructions.

ACCESSORY OFFERING SUMMARY

- Rolled Black Louvers & Decorative Filigree Panels in Black, Platinum, Brushed Brass.
- Rolled Louver Trim (Platinum, Brushed Brass).
- Perimeter Trim Kits (Black, Platinum, Brushed Brass).
- Cabinet Mantels For Wall and Corner Models
- Remote Control Kits
- Fan Kits
- Wall Mount Thermostat Kit
- Heat Deflection Hoods
- Fuel Conversion Kits
- Decorative Door Faces



Look For Us Online:
www.fmiproductions.com



IMPORTANT

Installation must be done by qualified service persons. Read Owner's Manual before using. Check local codes and ordinances for permitted uses. We reserve the right to amend product specifications without notice.

Operating heater at very high elevations could cause nuisance outages. Product cannot be converted between fuel types. For warranty information please consult the owner's manual.